



PARTS LIST FOR
MH-0125-3M1R

This Parts Listing has been compiled for your benefit. You can be assured your Mi-T-M Space Heater was constructed and designed with quality and performance in mind. Each component has been rigorously tested to insure the highest level of acceptance.

The contents of this Parts Listing are based on the latest product information available at the time of publication. Mi-T-M reserves the right to make changes in price, color, materials, equipment, specifications or models at any time without notice.

WARNING

THIS IS A PROFESSIONAL SPACE HEATER. CAUTION SHOULD BE OBSERVED WHEN USING OR REPAIRING THIS UNIT! READ AND FOLLOW THE SAFETY WARNINGS LISTED BELOW BEFORE ATTEMPTING ANY REPAIRS ON THIS SPACE HEATER!

SAFETY WARNINGS

1. NEVER alter or modify the equipment. Use only genuine Mi-T-M parts for repair of your space heater. Failure to do so can cause hazardous operating conditions and will VOID warranty.
2. Be thoroughly familiar with controls.
3. Before servicing the unit, turn unit off, and allow the unit to cool down. Do not make repairs while the unit is running. Service in a clean, dry, flat area. Block the wheels to prevent the unit from moving. Be especially careful to properly dispose of any flammable materials.

Table of Contents

SPECIFICATIONS.....3
FRAME ASSEMBLY4
WIRING DIAGRAM6

SPECIFICATIONS

Model	MH-0125-3M1R
Rating BTU/Hr	125,000
Volts/Hz/Amps	120/60Hz/5
Fuel Consumption (Gal/Hr)	0.85
Fuel Tank Capacity (Gallons)	14
Max Operating Hours	20
Heat Type	Radiant
Heating Area (Sq Ft)	3,125
Overheat Shut-Off System	Yes
Size (L x W x H)	28" x 37" x 42"
Weight (Lbs)	68.3 lbs

FRAME ASSEMBLY

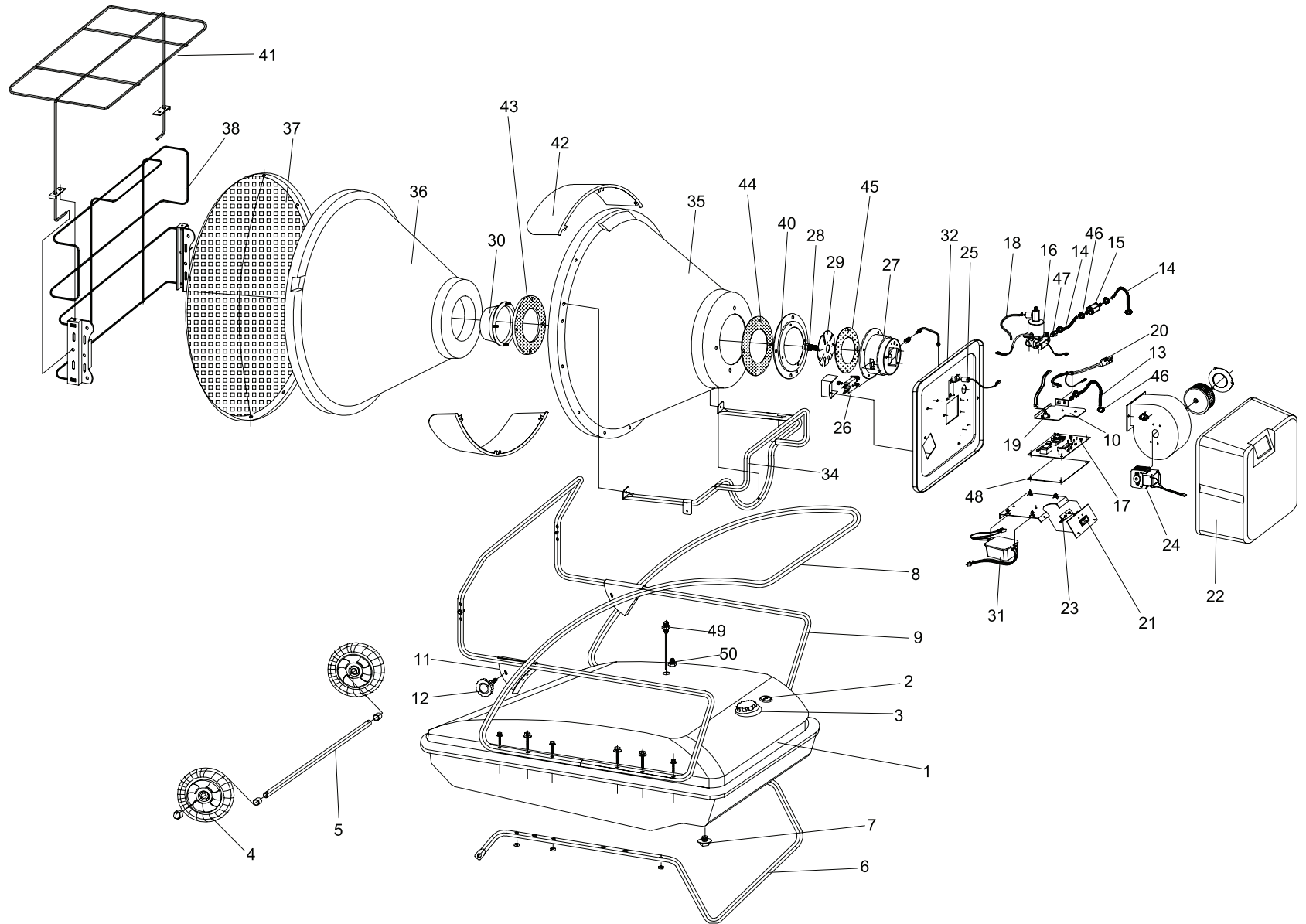

MH-0125-3M1R 010516 RSW

FRAME ASSEMBLY

ITEM NO.	ITEM DESCRIPTION	PART NO.	QTY.	ITEM NO.	ITEM DESCRIPTION	PART NO.	QTY.
1	FUEL TANK ASSEMBLY	68-3311	1	26	SPARK PLUG	68-3151	1
2	FUEL FILTER	68-3312	1	27	BURNER BODY	68-3152	1
3	FUEL TANK CAP ASSEMBLY	68-3313	1	28	NOZZLE	68-3153	1
4	WHEEL	68-3314	2	29	BURNER BLADE	68-3154	1
5	AXLE	68-3172	1	30	DIFFUSION CAP	68-3324	1
6	WHEEL FRAME	68-3315	1	31	IGNITOR	68-3213	1
7	DRAIN BOLT	68-3221	1	32	BURNER SUPPORT PLATE	68-3240	1
8	TRANSPORT HANDLE	68-3316	1	33	TEMPERATURE OVERHEAT SENSOR	68-3325	1
9	REAR FRAME	68-3317	1	34	RADIANT CONE SUPPORT	68-3326	1
10	PUMP SUPPORT PLATE	68-3205	1	35	RADIANT CONE ASSEMBLY	68-3156	1
11	FRAME SUPPORT	68-3318	2	36	CERAMIC FIBER	68-3157	1
12	HEIGHT ADJUSTMENT KNOB	68-3124	2	37	HEAT PLATE	68-3158	1
13	RETURN FUEL LINE	68-3319	1	38	SAFETY GUARD	68-3335	1
14	INTAKE FUEL LINE	68-3320	1	39	FRONT FRAME	68-3327	1
15	FUEL FILTER ASSEMBLY	68-3321	1	40	BURNER BRACKET	68-3242	1
16	FUEL PUMP ASSEMBLY	68-3141	1	41	TOP SAFETY GUARD	68-3328	1
17	MAIN PCB AND FUSE	68-3322	1	42	RADIANT VISOR	68-3226	1
18	INTAKE FUEL HOSE	68-3209	1	43	RADIANT CONE GASKET	68-3227	1
19	TIP OVER SENSOR	68-3162	1	44	RADIANT CONE GASKET	68-3227	1
20	POWER CORD	68-3323	1	45	BURNER ASSEMBLY GASKET	68-3249	1
21	POWER SWITCH	68-3223	1	46	HOSE CLAMP	68-3329	2
22	BACK COVER	68-3239	1	47	BARBED PUMP FITTING	68-3330	1
23	PANEL SUB-PCB	68-3147	1	48	PCB BASE	N/A	1
24	BLOWER MOTOR ASSEMBLY	68-3149	1	49	LEFT BARBED TANK FITTING	68-3331	1
25	PHOTOCELL ASSEMBLY	68-3150	1	50	RIGHT BARBED TANK FITTING	68-3332	1

WIRING DIAGRAM

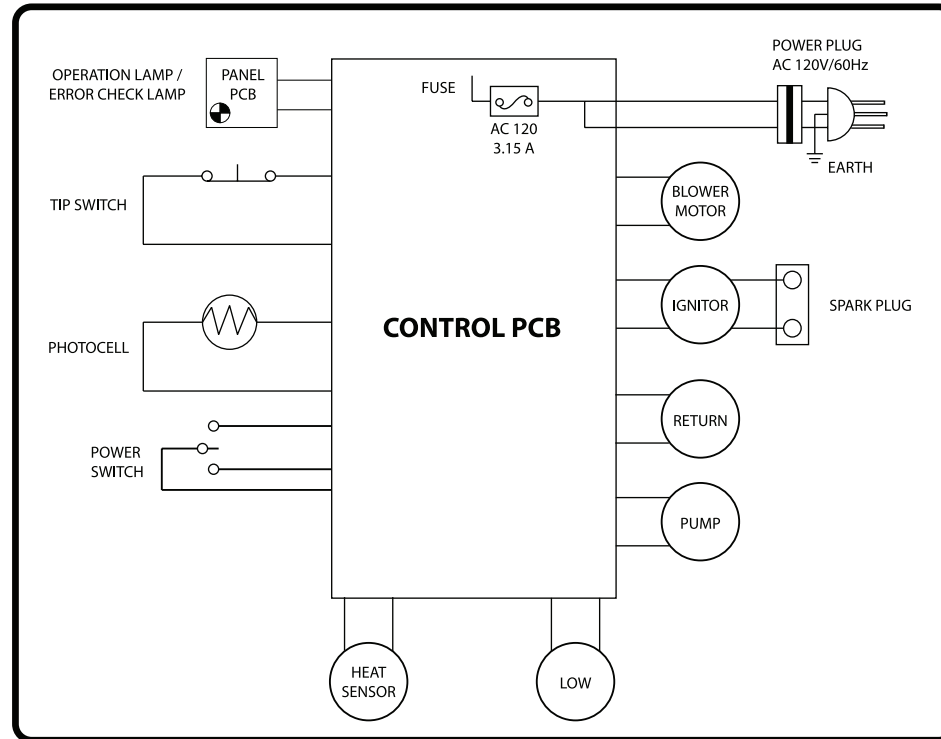

MH-0125-3M1R_WIRING DIAGRAM

Manufactured by Mi-T-M
50 Mi-T-M Drive, Peosta IA 52068
563-556-7484/ Fax 563-556-1235