



PARTS LIST FOR
WP-2500-4MHB
WP-2500-4MRB
(AFTER SERIAL #10817968)

ENGINE OIL GRADE:	
HONDA:	SAE10W-30
SUBARU	SAE10W-30
ENGINE OIL CAPACITY:	20 oz.
PUMP OIL GRADE:	SAE 20W-40
PUMP OIL CAPACITY:	5.0 oz.
NOZZLE SIZE:	3.0

This Parts Listing has been compiled for your benefit. You can be assured your Mi-T-M Cold Water Pressure Washer was constructed and designed with quality and performance in mind using over 25 years experience in the pressure washer business. Each component has been rigorously tested to insure the highest level of acceptance.

The contents of this Parts Listing are based on the latest product information available at the time of publication. Mi-T-M reserves the right to make changes in price, color, materials, equipment, specifications or models at any time without notice.

WARNING

THIS IS A HIGH PRESSURE, COLD WATER PRESSURE WASHER. CAUTION SHOULD BE OBSERVED WHEN USING OR REPAIRING THIS UNIT! READ AND FOLLOW THE SAFETY WARNINGS LISTED BELOW BEFORE ATTEMPTING ANY REPAIRS ON THIS PRESSURE WASHER!

SAFETY WARNINGS

1. NEVER alter or modify the equipment. Be sure any accessory items and system components being used will withstand the pressure developed. Use only genuine Mi-T-M parts for repair of your pressure washer. Failure to do so can cause hazardous operating conditions and will VOID warranty.
2. NEVER make adjustments on machinery while the unit is connected to the engine without first removing the ignition cable from the spark plug. Turning over the machinery by hand during adjustment or cleaning might start the engine and machinery with it, causing serious injury to the operator.
3. Know how to stop and bleed pressures quickly. Be thoroughly familiar with controls.
4. Before servicing the unit, turn unit off, relieve the water pressure and allow the unit to cool down. Do not make repairs while the unit is running. Service in a clean, dry, flat area. Be especially careful to properly dispose of any flammable materials.
5. After testing the machine, DO NOT leave the pressurized unit unattended. Shut off the unit and release trapped pressure before leaving.

TABLE OF CONTENTS

SPECIFICATIONS	3
NOTES	4
NOTES	5
FRAME ASSEMBLY WP-2500-4MHB (AFTER SERIAL #10817968)	6
FRAME ASSEMBLY WP-2500-4MRB (AFTER SERIAL #10817968)	8
PUMP ASSEMBLY 3-0411	10

SPECIFICATIONS

MODEL NUMBER	WP-2500-4MHB	WP-2500-4MRB
Operating Pressure (PSI/Bar):	2500/138	
High Pressure Nozzle:	3.0	
Water Volume (GPM/lpm):	2.3/8.7	
Engine:	Honda	Subaru
Model	GC160	EX170
Engine Type	4 Stroke, Overhead Valve, Single Cylinder	
Oil Type	SAE10W-30	
Oil Capacity (oz./liters)	20/.6	
Fuel Type	Unleaded Gasoline 86 Octane Minimum	
Fuel Capacity (gallon/ liters)	.5/2	.95/3.6
Starting	Recoil	
Maximum No Load RPM	3600 (+/- 100) RPM	
Pump:	Direct Driven, Oil Bath, Triplex Axial Piston	
Oil Type	SAE 20W-40	
Oil Capacity (oz./liters)	5.0/.15	
Plungers	Ceramic Coated	
Manifold	Forged Brass	
Valves	Stainless Steel	
Unloader	Preset	
Heat Dump Valve	Relieves heated water during unloader bypass stage	
Detergent Injector	Low pressure down stream from pump	
Unit Net Weight (lbs/Kg)	75/34	
Unit Shipping Weight (lbs/Kg)	87/39.5	
Unit Net Dimension (in/cm)	30Lx21Wx26H/76Lx53.5Wx66H	
Unit Shipping Dimension (in/cm)	30.5Lx21.5Wx26.5H/77.5Lx54.5Wx67.5H	

NOTES

SERIAL NUMBER BREAK

#10397982 (HONDA)

#10812415

#10817968 10-9-14

SERIAL NUMBER DISCRIPTION

CHANGED PUMP FROM 3-0260 TO 3-0311

CHANGED PUMP FROM 3-0311 TO 3-0411

REPLACED FRONT HANDLE 7-0194 WITH 7-0256

NOTES

FRAME ASSEMBLY WP-2500-4MHB (AFTER SERIAL #10817968)

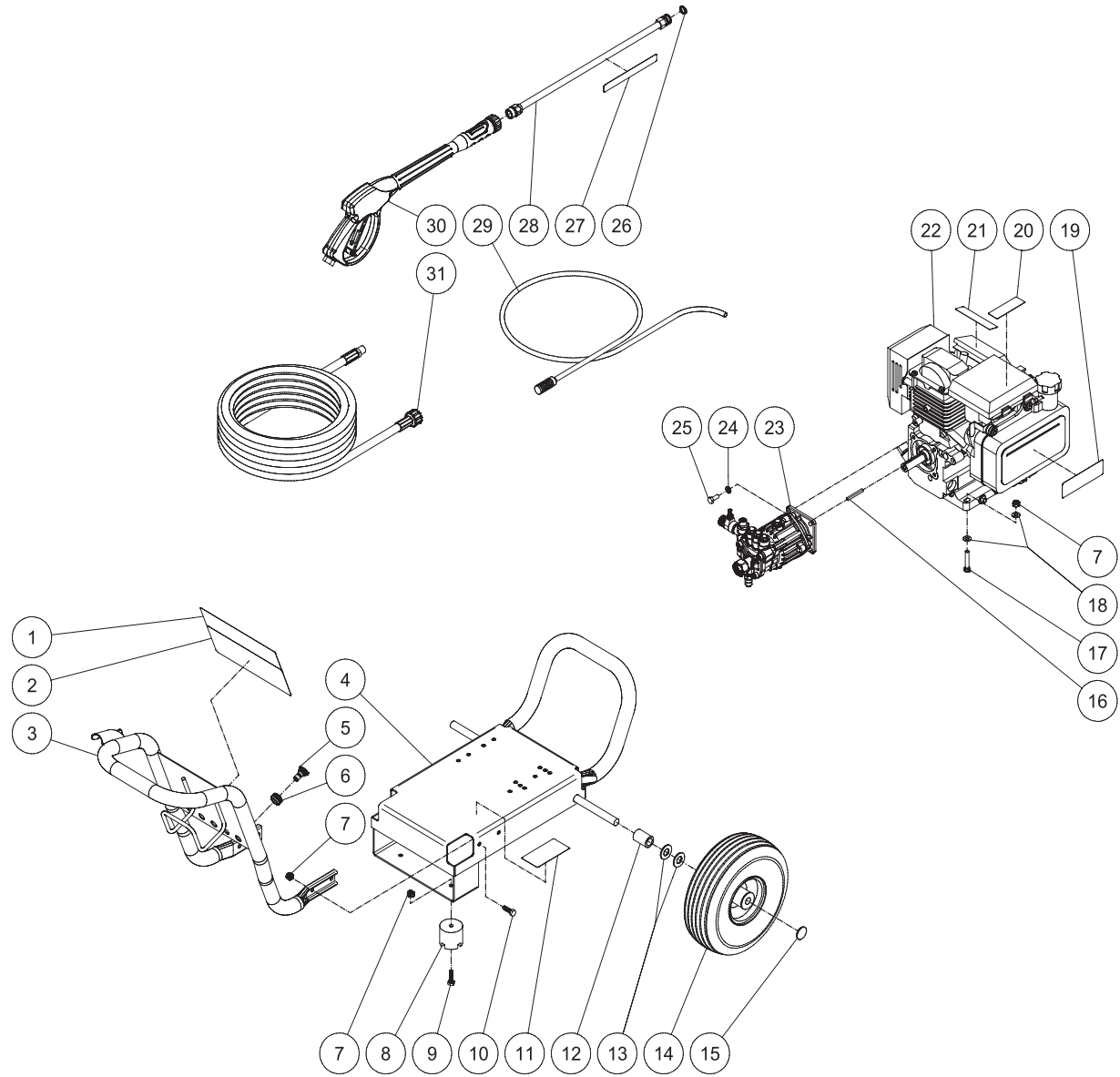

WP-2500-4MHB 100914 KMD

WP-2500-4MHB 100914 KMD			
FRAME ASSEMBLY			
ITEM	DESCRIPTION	PART #	QTY
1	DECAL	34-2904	1
2	DECAL - WARNING/CAUTION/OPERATION (SEE 71-1049)	N/A	1
3	HANDLE	7-0256A01	1
4	BASEPLATE	5-0253A53	1
5	NOZZLE	18-0386	1
-	NOZZLE	18-0388	1
-	NOZZLE	18-0390	1
6	GROMMET	33-0001	5
7	LOCKNUT	30-0157	10
8	ISOLATOR	14-0008	2
9	BOLT	27-0068	2
10	BOLT	27-0067	4
11	DECAL- SILVER STICKER	N/A	1
12	SPACER	62-0176	2
13	WASHER	28-0008	4
14	WHEEL	14-0130	2
15	CAP	33-0018	2
16	KEY	43-0073	1
17	BOLT	27-0070	4
18	WASHER	28-0003	8
19	DECAL - WORK PRO 2500 PSI	34-2204	1
20	DECAL - RISK OF FIRE (SEE 71-1049)	N/A	1
21	DECAL - RISK OF BURNS (SEE 71-1049)	N/A	1
22	ENGINE	1-0104	1
23	PUMP	3-0411	1
24	LOCKWASHER	29-0007	4
25	BOLT	27-0091	4
26	O-RING	25-0122	1
27	DECAL - RISK OF INJECTION (SEE 71-1049)	N/A	1
28	LANCE ASSEMBLY	16-0366	1
29	DETERGENT HOSE	19-0233	1
30	GUN & WAND - 4000 PSI	16-0441	1
31	HOSE	15-0269	1
-	DECAL SET	71-1049	1

FRAME ASSEMBLY WP-2500-4MRB (AFTER SERIAL #10817968)

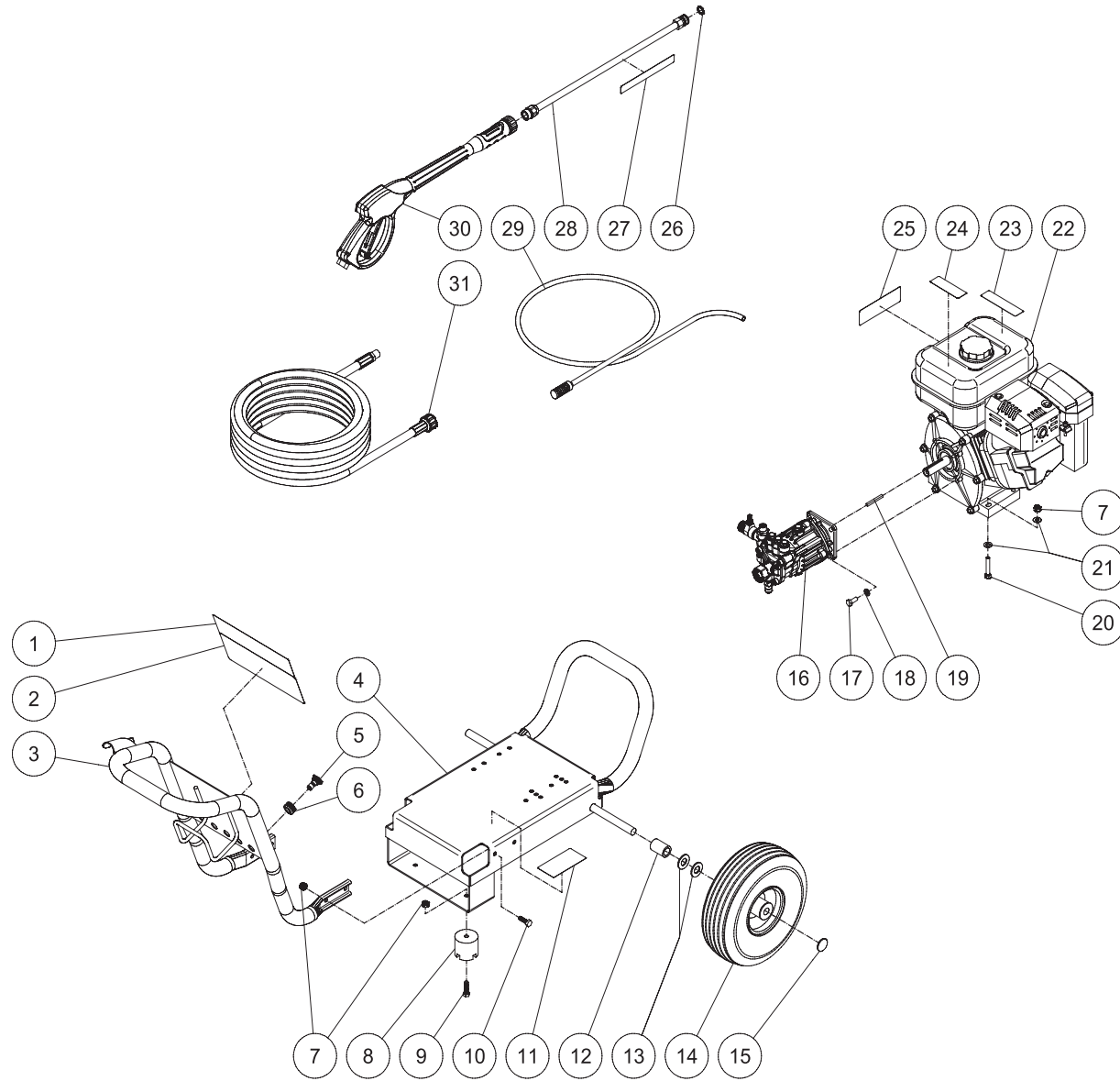

WP-2500-4MRB 101614 KMD

FRAME ASSEMBLY			
ITEM	DESCRIPTION	PART #	QTY
1	DECAL	34-2904	1
2	DECAL - WARNING/CAUTION/OPERATION (SEE 71-1049)	N/A	1
3	HANDLE	7-0256A01	1
4	BASEPLATE	5-0253A53	1
5	NOZZLE	18-0388	1
-	NOZZLE	18-0386	1
-	NOZZLE	18-0390	1
6	GROMMET	33-0001	5
7	LOCKNUT	30-0157	10
8	ISOLATOR	14-0008	2
9	BOLT	27-0068	2
10	BOLT	27-0067	4
11	DECAL- SILVER STICKER	N/A	1
12	SPACER	62-0176	2
13	WASHER	28-0008	4
14	WHEEL	14-0130	2
15	CAP	33-0018	2
16	PUMP	3-0411	1
17	BOLT	27-0091	4
18	LOCKWASHER	29-0007	4
19	KEY	43-0073	1
20	BOLT	27-0070	4
21	WASHER	28-0003	8
22	ENGINE	1-0190	1
23	DECAL - RISK OF BURNS (SEE 71-1049)	N/A	1
24	DECAL - RISK OF FIRE (SEE 71-1049)	N/A	1
25	DECAL (SEE KIT 71-1049)	N/A	1
26	O-RING	25-0122	1
27	DECAL - RISK OF INJECTION (SEE 71-1049)	N/A	1
28	LANCE ASSEMBLY	16-0366	1
29	DETERGENT HOSE	19-0233	1
30	GUN & WAND - 4000 PSI	16-0441	1
31	HOSE	15-0269	1
-	DECAL SET	71-1049	1

PUMP ASSEMBLY 3-0411

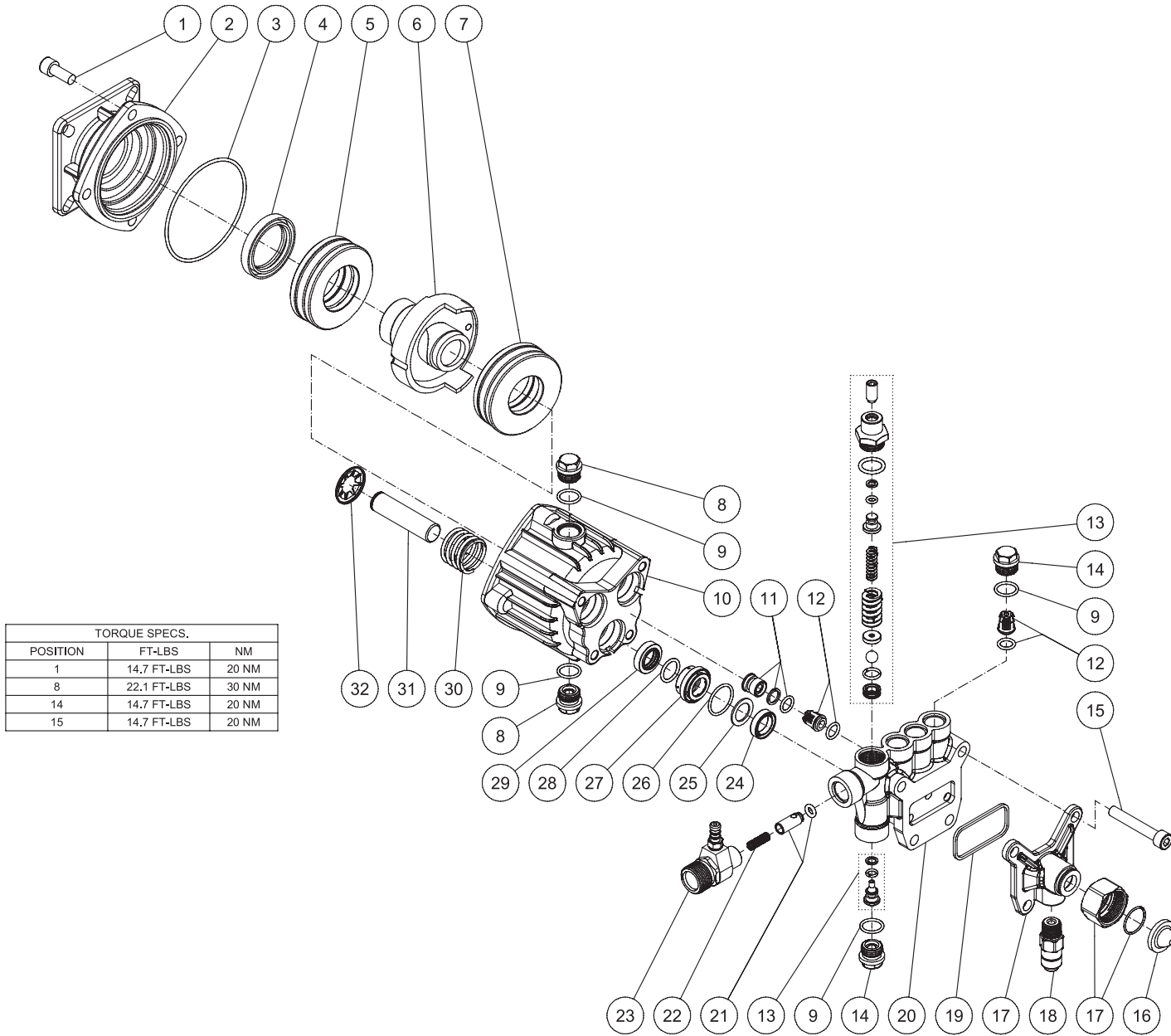

3-0411 080714 KMD

3-0411 080714 KMD			
PUMP ASSEMBLY			
ITEM	DESCRIPTION	PART #	QTY
1	SCREW	27-8432	4
2	FLANGE	46-1330	1
3	O-RING	25-0605	1
4	OIL SEAL	26-0320	1
5	REAR BEARING	N/A	1
6	WOBBLE PLATE ASSEMBLY	N/A	1
7	FRONT BEARING	N/A	1
8	PLUG	39-0233	2
9	O-RING	25-0606	6
10	PUMP HOUSING	N/A	1
11	KIT - INLET PLUG ASSEMBLY (SEE KIT 70-0512)	SEE KIT	3
12	VALVE ASSEMBLY (SEE KIT 70-0516)	SEE KIT	6
13	KIT - COMPLETE UNLOADER	70-0646	1
14	PLUG	39-0372	4
15	BOLT	27-9569	4
16	FILTER	19-0001	1
17	KIT- INLET ASSEMBLY	70-0514	1
18	THERMAL RELIEF VALVE	22-0408	1
19	INLET BODY SEAL	26-0327	1
20	PUMP HEAD	N/A	1
21	KIT - NON-RETURN VALVE	70-0511	1
22	NON-RETURN VALVE SPRING	46-1332	1
23	KIT - OUTLET/BARB ASSEMBLY	70-0510	1
24	WATER SEAL (SEE KIT 70-0515)	SEE KIT	3
25	WATER SEAL WASHER (SEE KIT 70-0515)	SEE KIT	3
26	O-RING (SEE KIT 70-0515)	SEE KIT	3
27	LOCATING RING	46-1586	3
28	O-RING (SEE KIT 70-0515)	SEE KIT	3
29	OIL SEAL	26-0325	3
30	PLUNGER SPRING	N/A	3
31	PISTON	46-1587	3
32	SPRING DISK	N/A	3

REPLACEMENT KITS				
KIT #	DESCRIPTION	ITEMS	# OF ASSEMBLIES	# OF CYLINDERS
70-0512	KIT - INLET PLUG	11	3	3
70-0515	KIT - PACKINGS	24, 25, 26, 28	3, 3, 3, 3	3
70-0516	KIT - VALVES W/ O-RING	12	6	3

Manufactured by Mi-T-M
8650 Enterprise Drive, Peosta IA 52068
563-556-7484/ Fax 563-556-1235