



PARTS LIST FOR
CA-3504-1MGH
(AFTER SERIAL #10754656)

Engine Oil Grade:	SAE 10W-30
Engine Oil Capacity:	37 oz.
Pump Oil Grade:	Mi-T-M Pump Oil #AW-4085-0016
Pump Oil Capacity:	14 oz.
Nozzle Size:	4.0

This Parts Listing has been compiled for your benefit. You can be assured your Mi-T-M Cold Water Pressure Washer was constructed and designed with quality and performance in mind using over 25 years experience in the pressure washer business. Each component has been rigorously tested to insure the highest level of acceptance.

The contents of this Parts Listing are based on the latest product information available at the time of publication. Mi-T-M reserves the right to make changes in price, color, materials, equipment, specifications or models at any time without notice.

WARNING

THIS IS A PROFESSIONAL HIGH PRESSURE, COLD WATER PRESSURE WASHER. CAUTION SHOULD BE OBSERVED WHEN USING OR REPAIRING THIS UNIT! READ AND FOLLOW THE SAFETY WARNINGS LISTED BELOW BEFORE ATTEMPTING ANY REPAIRS ON THIS PRESSURE WASHER!

SAFETY WARNINGS

1. NEVER alter or modify the equipment. Be sure any accessory items and system components being used will withstand the pressure developed. Use only genuine Mi-T-M parts for repair of your pressure washer. Failure to do so can cause hazardous operating conditions and will VOID warranty.
2. NEVER make adjustments on machinery while the unit is connected to the engine without first removing the ignition cable from the spark plug. Turning over the machinery by hand during adjustment or cleaning might start the engine and machinery with it, causing serious injury to the operator.
3. Know how to stop and bleed pressures quickly. Be thoroughly familiar with controls.
4. Before servicing the unit, turn unit off, relieve the water pressure and allow the unit to cool down. Do not make repairs while the unit is running. Service in a clean, dry, flat area. Block the wheels to prevent the unit from moving. Be especially careful to properly dispose of any flammable materials.
5. After testing the machine, DO NOT leave the pressurized unit unattended. Shut off the unit and release trapped pressure before leaving.

TABLE OF CONTENTS

SPECIFICATIONS.....	3
NOTES	4
FRAME ASSEMBLY FOR CA-3504-1MGH (AFTER SERIAL #10754656)	6
PUMP ASSEMBLY (3-0350)	8
UNLOADER ASSEMBLY (8-0633)	10

SPECIFICATIONS

MODEL NUMBER	CA-3504-1MGH
Operating Pressure (PSI/Bar):	3500/241.3
High Pressure Nozzle:	4.0
Water Volume (GPM/lpm):	4.0/15.1
Engine:	Honda
Model	GX390
Engine Type	4 Stroke, Overhead Valve, Single Cylinder
Oil Type	SAE 10W-30
Oil Capacity (oz./liters)	37/1.1
Low Oil Protection	Oil Alert™
Fuel Type	Unleaded Gasoline 86 Octane Minimum
Fuel Capacity (gallon/ liters)	1.61/6.1
Starting	Recoil
Maximum No Load RPM	3600 (+/- 100) RPM
Pump:	Direct Driven, Oil Bath, Triplex Piston
Oil Type	Mi-T-M Pump Oil #AW-4085-0016
Oil Capacity (oz./liters)	14/0.4
Plungers	Ceramic
Manifold	Forged Brass
Valves	Stainless Steel
Unloader	Adjustable
Thermal Relief Valve	Relieves heated water during unloader bypass stage
Unit Net Weight (lbs/Kg)	125/57
Unit Shipping Weight (lbs/Kg)	175/79.5
Unit Net Dimension (in/cm)	42.5Lx23.5Wx25H/108Lx60Wx63.5H
Unit Shipping Dimension (in/cm)	39.5Hx25Wx31.5H/100.5Lx63.5Wx80H

NOTES

DATE	SERIAL #	REASON FOR CHANGE
11/12/13	#10754656	CHANGED AXLE

NOTES

FRAME ASSEMBLY FOR CA-3504-1MGH (AFTER SERIAL #10754656)

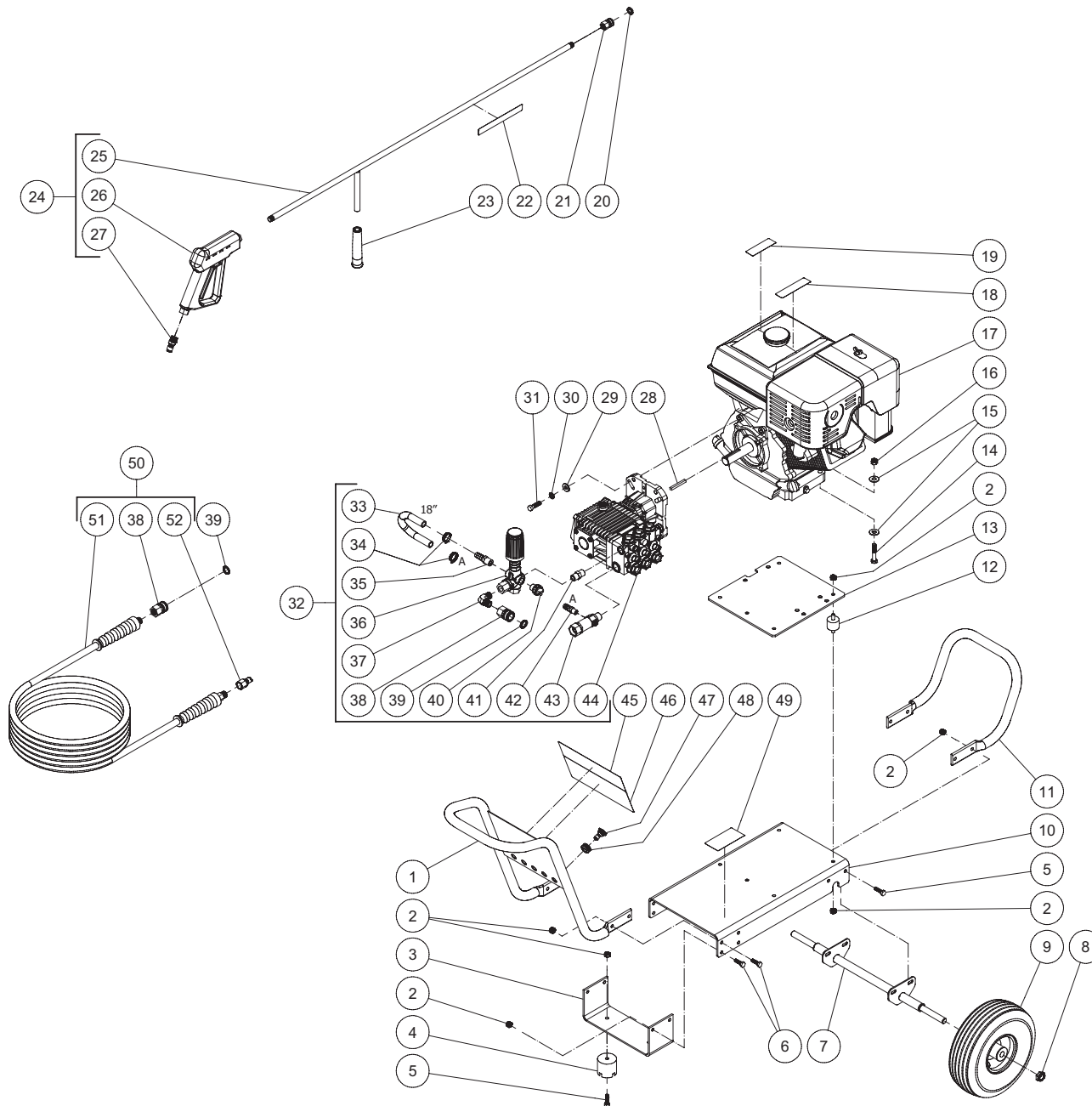

CA-3504-1MGH-101613-CH

FRAME ASSEMBLY

ITEM	DESCRIPTION	PART #	QTY	ITEM	DESCRIPTION	PART #	QTY
1	HANDLE	7-0182	1	29	WASHER	28-0022	4
2	LOCKNUT	30-0157	22	30	LOCKWASHER	29-0008	4
3	BRACKET	56-0054	1	31	BOLT	27-0118	4
4	ISOLATOR	14-0008	2	32	PUMP W/EXTERNAL BYPASS (33-44)	851-0375	1
5	BOLT	27-0068	6	33	HOSE *(TWO FEET REQUIRED)	15-0007	1
6	BOLT	27-0067	8	34	HOSE CLAMP	42-0011	2
7	AXLE	13-0230A53	1	35	HOSE BARB	23-0105	1
8	LOCKNUT	30-0117	2	36	UNLOADER	8-0633	1
9	WHEEL	14-0130	2	37	ELBOW	24-0131	1
10	BASEPLATE	5-0207	1	38	QC SOCKET	17-0004	2
11	HANDLE	7-0183	1	39	O-RING	25-0123	2
12	ISOLATOR	14-0097	4	40	HEAT DUMP VALVE	22-0114	1
13	ISOLATION PLATE	56-0053	1	41	NIPPLE	24-0010	1
14	BOLT	27-0121	4	42	HOSE BARB	23-0120	1
15	WASHER	28-0023	8	43	FILTER	19-0207	1
16	LOCKNUT	30-0159	4	44	PUMP	3-0350	1
17	ENGINE - HONDA	1-0086	1	45	DECAL	N/A	1
18	DECAL - RISK OF BURNS (SEE 71-0065)	N/A	1	46	DECAL - WARNING/CAUTION/OPERATION (SEE 71-0065)	N/A	1
19	DECAL - RISK OF FIRE (SEE 71-0065)	N/A	1	47	NOZZLE	18-0397	1
20	O-RING	25-0122	1	-	NOZZLE	18-0399	1
21	QUICK CONNECT	17-0001	1	-	NOZZLE	18-0400	1
22	DECAL - RISK OF INJECTION (SEE 71-0065)	N/A	1	48	GROMMET	33-0001	5
23	GRIP	7-0002	1	49	DECAL - SILVER STICKER	N/A	1
24	GUN/WAND ASSEMBLY (25-27)	851-0371	1	50	PRESSURE HOSE ASSEMBLY (38, 51-52)	851-0338	1
25	WAND (INC GRIP & QC)	16-0439	1	51	HOSE	15-0209	1
26	GUN	16-0001	1	52	QUICK CONNECT	17-0006	1
27	QUICK CONNECT	17-0005	1	-	DECAL SET	71-0065	1
28	KEY	43-0078	1	*MUST ORDER IN ONE FOOT LENGTHS			

PUMP ASSEMBLY (3-0350)

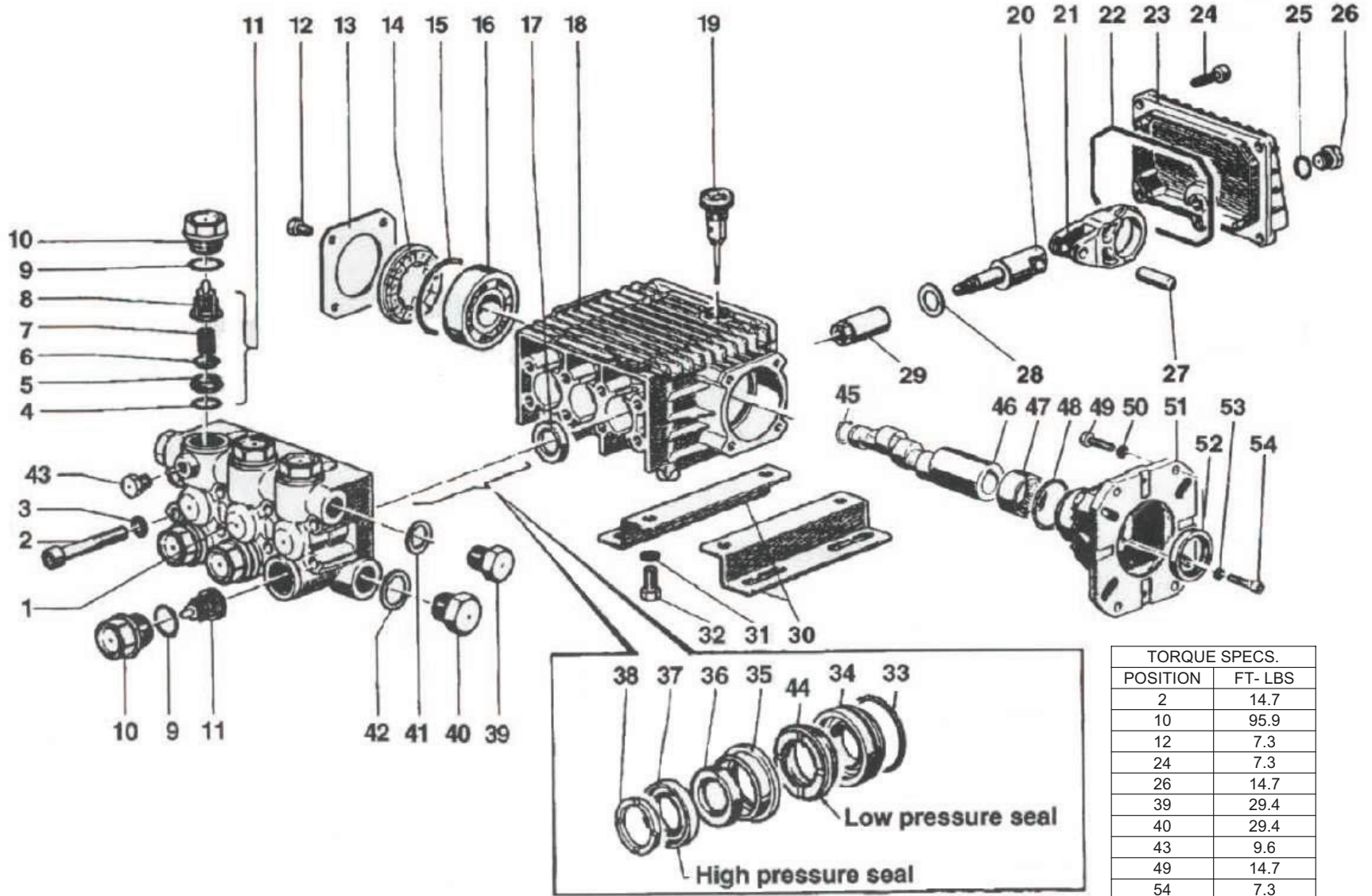

TORQUE SPECS.	
POSITION	FT-LBS
2	14.7
10	95.9
12	7.3
24	7.3
26	14.7
39	29.4
40	29.4
43	9.6
49	14.7
54	7.3

PUMP ASSEMBLY

ITEM	DESCRIPTION	PART #	QTY	ITEM	DESCRIPTION	PART #	QTY
1	MANIFOLD	46-1391	1	28	WASHER	46-1395	3
2	BOLT	27-8439	8	29	PLUNGER, 13 mm	46-1396	3
3	WASHER	29-0154	8	30	RAIL	-	2
4	O-RING (SEE KIT 70-0028)	25-0053	6	31	WASHER	-	4
5	VALVE SEAT (SEE KIT 70-0028)	SEE KIT	6	32	NUT	-	4
6	VALVE PLATE (SEE KIT 70-0028)	SEE KIT	6	33	O-RING (SEE KIT 70-0552)	SEE KIT	3
7	VALVE SPRING (SEE KIT 70-0028)	SEE KIT	6	34	PACKING RETAINER (SEE KIT 70-0552)	SEE KIT	3
8	VALVE CAGE (SEE KIT 70-0028)	SEE KIT	6	35	INTERMEDIATE RING (SEE KIT 70-0552)	SEE KIT	3
9	O-RING	25-0012	6	36	PACKING (SEE KIT 70-0552 & 70-0553)	SEE KIT	3
10	VALVE PLUG	39-0071	6	37	PACKING (SEE KIT 70-0552 & 70-0553)	SEE KIT	3
11	VALVE ASSEMBLY (SEE KIT 70-0028)	46-0565	6	38	HEAD RING (SEE KIT 70-0552)	SEE KIT	3
12	BOLT	27-8000	4	39	CAP SCREW	39-0018	1
13	COVER/CRANKCASE CLOSED	46-0084	1	40	CAP SCREW	39-0019	1
14	SPACER	46-0574	1	41	WASHER	28-0600	1
15	O-RING	25-0060	1	42	WASHER	46-1402	1
16	BALL BEARING	46-1392	1	43	CAP SCREW	39-0032	1
17	OIL SEAL (SEE KIT 70-0391)	26-0046	3	44	SEAL, LOW PRESS (SEE KIT 70-0552 & 70-0553)	SEE KIT	1
18	CRANKCASE	46-0570	1	45	RETAINING RING	46-0104	1
19	OIL DIPSTICK	46-0143	1	46	CRANKSHAFT	46-1404	1
20	PISTON GUIDE	46-1393	3	47	ROLLER BEARING	48-0040	1
21	CONNECTING ROD	46-0572	3	48	O-RING	25-0316	1
22	O-RING	46-1394	1	49	BOLT	-	4
23	REAR COVER	46-0571	1	50	WASHER	-	4
24	BOLT	24-8401	5	51	GAS FLANGE	38-0038	1
25	O-RING	25-0014	1	52	OIL SEAL	26-0181	1
26	CAP SCREW	39-0017	1	53	WASHER	29-0153	4
27	PIN	43-0079	3	54	SCREW	27-8404	4

REPLACEMENT KITS

KIT #	DESCRIPTION	ITEMS	# OF ASSEMBLIES	# OF CYLINDERS
70-0028	KIT - VALVE	4,5,6,7,8,11	6,6,6,6,6,6	3
70-0391	KIT - OIL SEAL	17	3	3
70-0552	KIT - PRESSURE SEAL	33,34,35,36,37,38,44	1,1,1,1,1,1,1	1
70-0553	KIT - GENERAL PRESSURE SEAL	36,37,44	3,3,3	3

UNLOADER ASSEMBLY (8-0633)

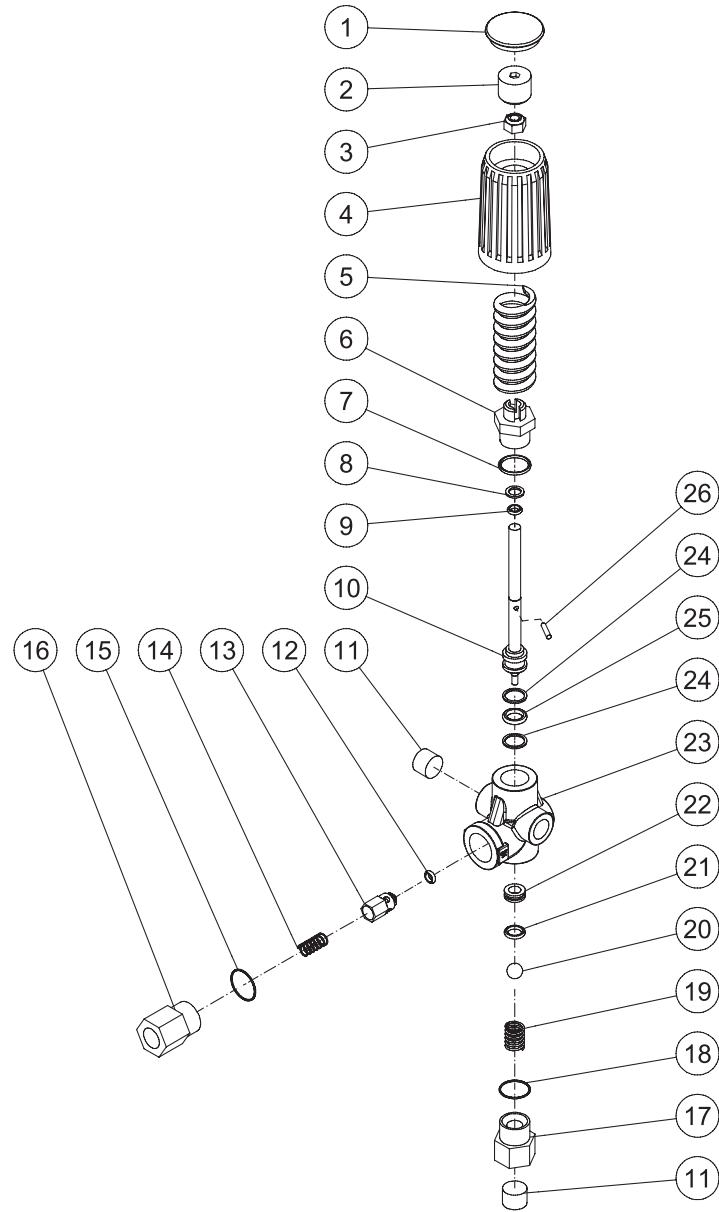

UNLOADER			
ITEM	DESCRIPTION	PART #	QTY
1	CAP	39-0252	1
2	NUT	46-1528	1
3	LOCKNUT	30-3156	1
4	KNOB	7-0242	1
5	SPRING	49-0171	1
6	FITTING	46-1529	1
7	O-RING (SEE KIT 70-0625)	SEE KIT	1
8	O-RING (SEE KIT 70-0625)	SEE KIT	1
9	O-RING (SEE KIT 70-0625)	SEE KIT	1
10	STEM	46-1530	1
11	PLUG	23-0244	2
12	O-RING (SEE KIT 70-0624)	SEE KIT	1
13	POPPET (SEE KIT 70-0624)	SEE KIT	1
14	SPRING (SEE KIT 70-0624)	SEE KIT	1
15	O-RING	25-0672	1
16	OUTLET FITTING	46-1531	1
17	INLET FITTING (SEE KIT 70-0625)	SEE KIT	1
18	O-RING (SEE KIT 70-0625)	SEE KIT	1
19	SPRING	49-0172	1
20	BALL (SEE KIT 70-0625)	SEE KIT	1
21	O-RING (SEE KIT 70-0625)	SEE KIT	1
22	SEAT	46-1532	1
23	FORGING	46-1533	1
24	BACKUP RING (SEE KIT 70-0625)	SEE KIT	2
25	O-RING (SEE KIT 70-0625)	SEE KIT	1
26	PIN (SEE KIT 70-0625)	SEE KIT	1

REPLACEMENT KITS			
KIT #	DESCRIPTION	ITEMS	QTY
70-0624	KIT - CHECK VALVE	12-14	1, 1, 1
70-0625	KIT - UNLOADER REBUILD	7-9, 17, 18, 20, 21, 24-26	1, 1, 1, 1, 1, 1, 1, 2, 1, 1

Manufactured by Mi-T-M
8650 Enterprise Drive, Peosta IA 52068
563-556-7484/ Fax 563-556-1235