



PARTS LIST FOR
WP-3200-0MHB
WP-3200-0MKB
WP-3200-0MSB
(AFTER SERIAL #10854374)

ENGINE OIL GRADE:	SAE10W-30
ENGINE OIL CAPACITY:	20 oz.
PUMP OIL GRADE:	Mi-T-M Pump Oil AW-4085-0016
PUMP OIL CAPACITY:	16.9 oz.
NOZZLE SIZE:	3.0

This Parts Listing has been compiled for your benefit. You can be assured your Mi-T-M Cold Water Pressure Washer was constructed and designed with quality and performance in mind using over 25 years experience in the pressure washer business. Each component has been rigorously tested to insure the highest level of acceptance.

The contents of this Parts Listing are based on the latest product information available at the time of publication. Mi-T-M reserves the right to make changes in price, color, materials, equipment, specifications or models at any time without notice.

WARNING

THIS IS A HIGH PRESSURE, COLD WATER PRESSURE WASHER. CAUTION SHOULD BE OBSERVED WHEN USING OR REPAIRING THIS UNIT! READ AND FOLLOW THE SAFETY WARNINGS LISTED BELOW BEFORE ATTEMPTING ANY REPAIRS ON THIS PRESSURE WASHER!

SAFETY WARNINGS

1. NEVER alter or modify the equipment. Be sure any accessory items and system components being used will withstand the pressure developed. Use only genuine Mi-T-M parts for repair of your pressure washer. Failure to do so can cause hazardous operating conditions and will VOID warranty.
2. NEVER make adjustments on machinery while the unit is connected to the engine without first removing the ignition cable from the spark plug. Turning over the machinery by hand during adjustment or cleaning might start the engine and machinery with it, causing serious injury to the operator.
3. Know how to stop and bleed pressures quickly. Be thoroughly familiar with controls.
4. Before servicing the unit, turn unit off, relieve the water pressure and allow the unit to cool down. Do not make repairs while the unit is running. Service in a clean, dry, flat area. Be especially careful to properly dispose of any flammable materials.
5. After testing the machine, DO NOT leave the pressurized unit unattended. Shut off the unit and release trapped pressure before leaving.

Table of Contents

SPECIFICATIONS	3
NOTES	4
NOTES	5
FRAME ASSEMBLY (AFTER SERIAL #10845374)	6
MOTOR / PUMP ASSEMBLY (3-0414)	8
UNLOADER (8-0632)	10

SPECIFICATIONS

MODEL NUMBER	WP-3200-0MHB	WP-3200-0MKB	WP-3200-0MSB
Operating Pressure (PSI/Bar):	3200/221		
High Pressure Nozzle:	3.0		
Water Volume (GPM/lpm):	2.4/9.1		
Engine:	Honda	Kohler	Subaru
Model	GX200	CH270	EX21
Engine Type	4 Stroke, Overhead Valve, Single Cylinder		4 Stroke, Overhead Cam, Single Cylinder
Oil Type	SAE10W-30		
Oil Capacity (oz./liters)	20/.6		
Fuel Type	Unleaded Gasoline 86 Octane Minimum		
Low Oil Protection	Oil Alert™		Oil Sensor
Fuel Capacity (gallon/ liters)	.95/3.6		
Starting	Recoil		
Maximum No Load RPM	3600 (+/- 100) RPM		
Pump:	Direct Driven, Oil Bath, Triplex Piston		
Oil Type	Mi-T-M Pump Oil AW-4085-0016		
Oil Capacity (oz./liters)	16.9/.50		
Plungers	Ceramic Coated		
Manifold	Forged Brass		
Valves	Stainless Steel		
Unloader	Preset		
Heat Dump Valve	Relieves heated water during unloader bypass stage		
Detergent Injector	Low pressure down stream from pump		
Unit Net Weight (lbs/Kg)	85/38.6		
Unit Shipping Weight (lbs/Kg)	102/46.3		
Unit Net Dimension (in/cm)	23.25Lx20.25Wx20.75H/59.1Lx51.4Wx52.7H		
Unit Shipping Dimension (in/cm)	29.375Lx20.625Wx27.5H/74.6Lx52.4Wx69.8H		

NOTES

DATE	SERIAL #	REASON
03-02-15	10845374	CHANGED PUMP FROM 3-0297 TO 3-0414

NOTES

FRAME ASSEMBLY (AFTER SERIAL #10845374)

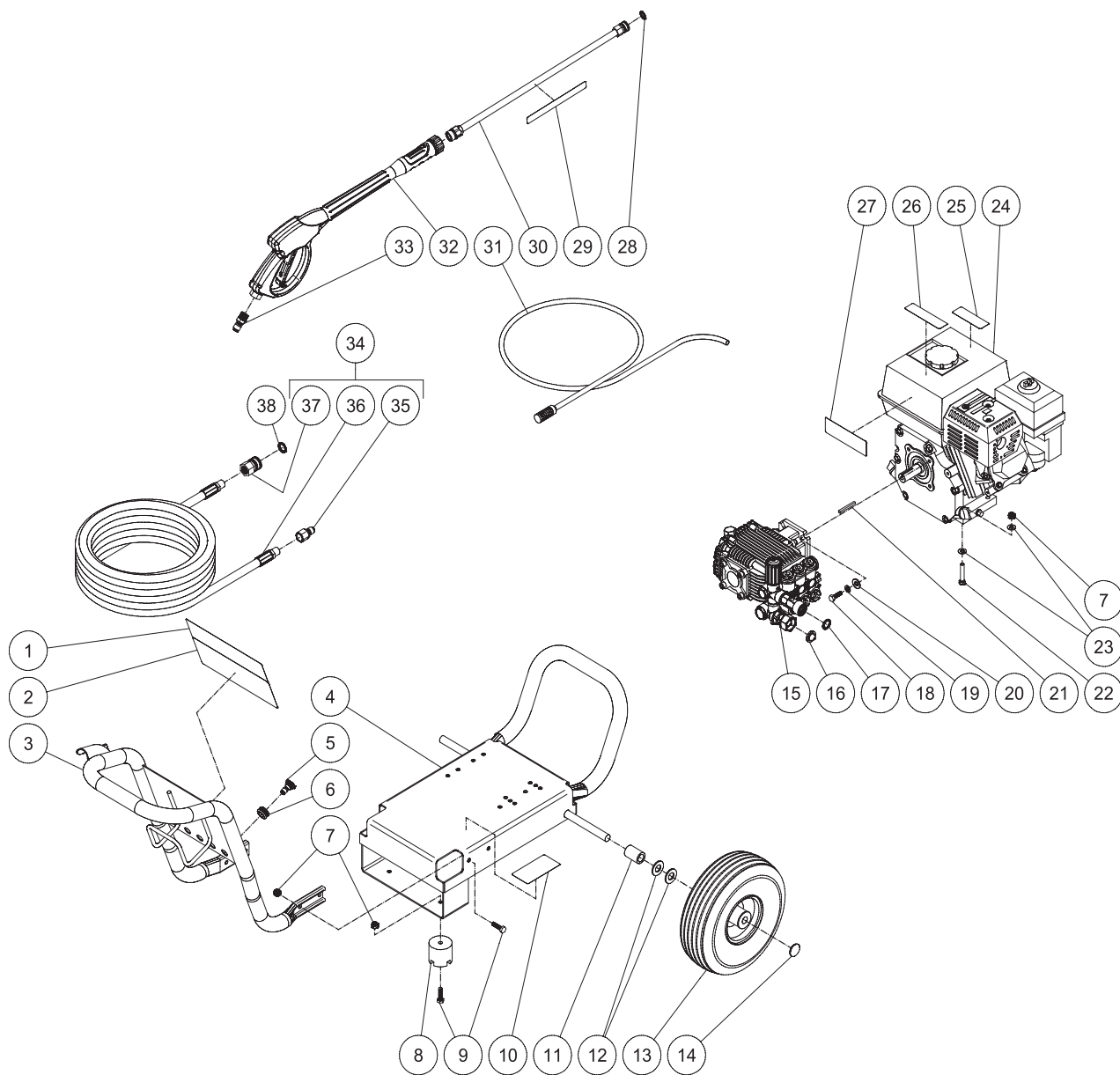

WP-3000-4MHB_K_R 022715 JDK

WP-3000-4MHB_K_R 022715 JDK			
FRAME ASSEMBLY			
ITEM	DESCRIPTION	PART #	QTY
1	DECAL	34-2907	1
2	DECAL - WARNING/CAUTION/OPERATION (SEE 71-1049)	N/A	1
3	HANDLE	7-0256A01	1
4	BASEPLATE	5-0253A53	1
5	NOZZLE 15030	18-0388	1
-	NOZZLE 65400	18-0386	1
-	NOZZLE 25030	18-0390	1
6	GROMMET	33-0001	5
7	LOCKNUT	30-0157	10
8	ISOLATOR	14-0008	2
9	BOLT	27-0068	6
10	DECAL- SILVER STICKER	N/A	1
11	SPACER	62-0176	2
12	WASHER	28-0008	4
13	WHEEL	14-0130	2
14	CAP	33-0018	2
15	PUMP	3-0414	1
16	FILTER	19-0001	1
17	O-RING	25-0123	2
18	BOLT	27-0092	4
19	LOCKWASHER	29-0007	4
20	WASHER	28-0022	4
21	KEY	43-0073	1
22	BOLT	27-0070	4
23	WASHER	28-0003	8
24	ENGINE HONDA	1-0088	1
-	ENGINE SUBARU	1-0133	1
-	ENGINE KOHLER	1-0206	1
25	DECAL - RISK OF FIRE (SEE 71-1049)	N/A	1
26	DECAL - RISK OF BURNS (SEE 71-1049)	N/A	1
27	DECAL (SEE KIT 71-1049)	34-2774	1
28	O-RING	25-0122	1
29	DECAL - RISK OF INJECTION (SEE 71-1049)	N/A	1
30	LANCE ASSEMBLY	16-0366	1
31	DETERGENT HOSE	19-0233	1
32	GUN & WAND	16-0441	1
33	QUICK CONNECT	17-0005	1
34	HOSE W/QC ENDS	15-0277	1
35	QUICK CONNECT	17-0006	1
36	HOSE	N/A	1
37	QC SOCKET	17-0004	1
38	O-RING	25-0123	1
-	DECAL SET	71-1049	1

MOTOR / PUMP ASSEMBLY (3-0414)

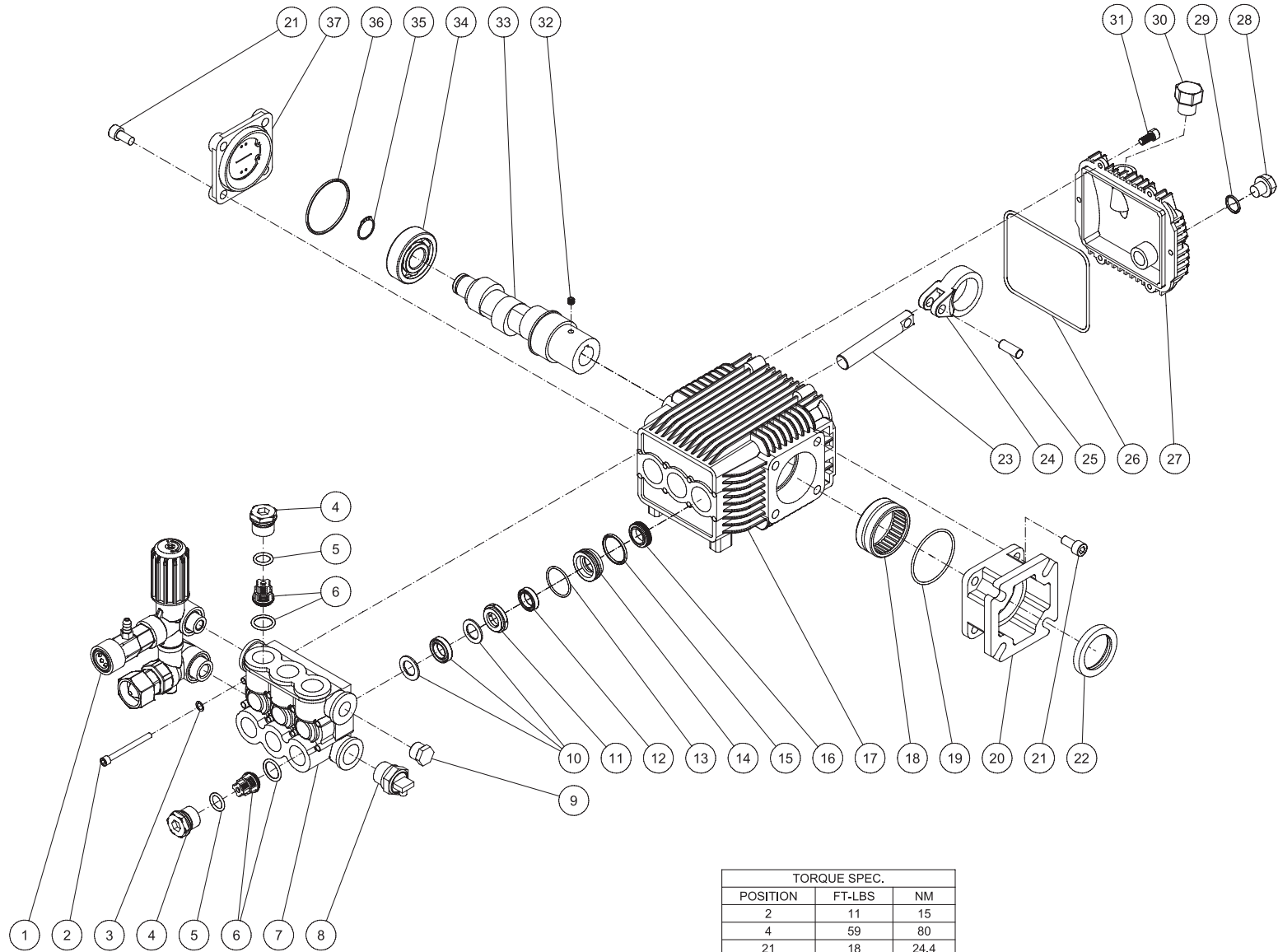

TORQUE SPEC.		
POSITION	FT-LBS	NM
2	11	15
4	59	80
21	18	24.4
30	7.4	10

3-0414 030915 JDK

3-0414 030915 JDK			
PUMP ASSEMBLY			
ITEM	DESCRIPTION	PART #	QTY
1	UNLOADER	8-0632	1
2	BOLT	27-0898	8
3	WASHER	28-0203	8
4	VALVE PLUG	39-0231	6
5	O-RING	25-0622	6
6	VALVE ASSEMBLY (SEE KIT 70-0502)	70-0502	6
7	MANIFOLD HEAD	46-1503	1
8	RELIEF VALVE	22-0005	1
9	PLUG	39-0102	1
10	HIGH PRESSURE PACKING (SEE KIT 70-0501)	SEE KIT	3
11	SEAL COMPACTION RING	46-1311	3
12	LOW PRESSURE SEAL (SEE KIT 70-0501)	SEE KIT	3
13	O-RING (SEE KIT 70-0501)	SEE KIT	3
14	RETAINER RING	46-1312	3
15	O-RING	25-0663	3
16	OIL SEAL	46-1313	3
17	CRANKCASE	N/A	1
18	NEEDLE BEARING	48-0096	1
19	O-RING	25-0603	1
20	FLANGE	46-1314	1
21	BOLT	27-8431	8
22	OIL SEAL	26-0320	1
23	PISTON - COATED	46-1504	3
24	CONNECTING ROD	46-1595	3
25	PISTON - PIN	46-1505	3
26	O-RING	25-0604	1
27	CRANKCASE COVER	46-1594	1
28	DRAIN PLUG	39-0376	1
29	O-RING	25-0606	1
30	OIL CAP	46-1593	1
31	BOLT	27-8401	6
32	SET SCREW	27-8886	1
33	CRANKSHAFT	N/A	1
34	BALL BEARING	48-0102	1
35	SNAP RING	46-1596	1
36	O-RING	25-0634	1
37	SIGHT GLASS ASSEMBLY	46-1597	1

REPLACEMENT KITS				
KIT #	DESCRIPTION	ITEMS	# OF ASSEMBLIES	# OF CYLINDERS
70-0501	KITS - PACKINGS	10, 12, 13	3, 3, 3	3
70-0502	KITS - VALVES W/ O-RING	6	6	3

UNLOADER (8-0632)

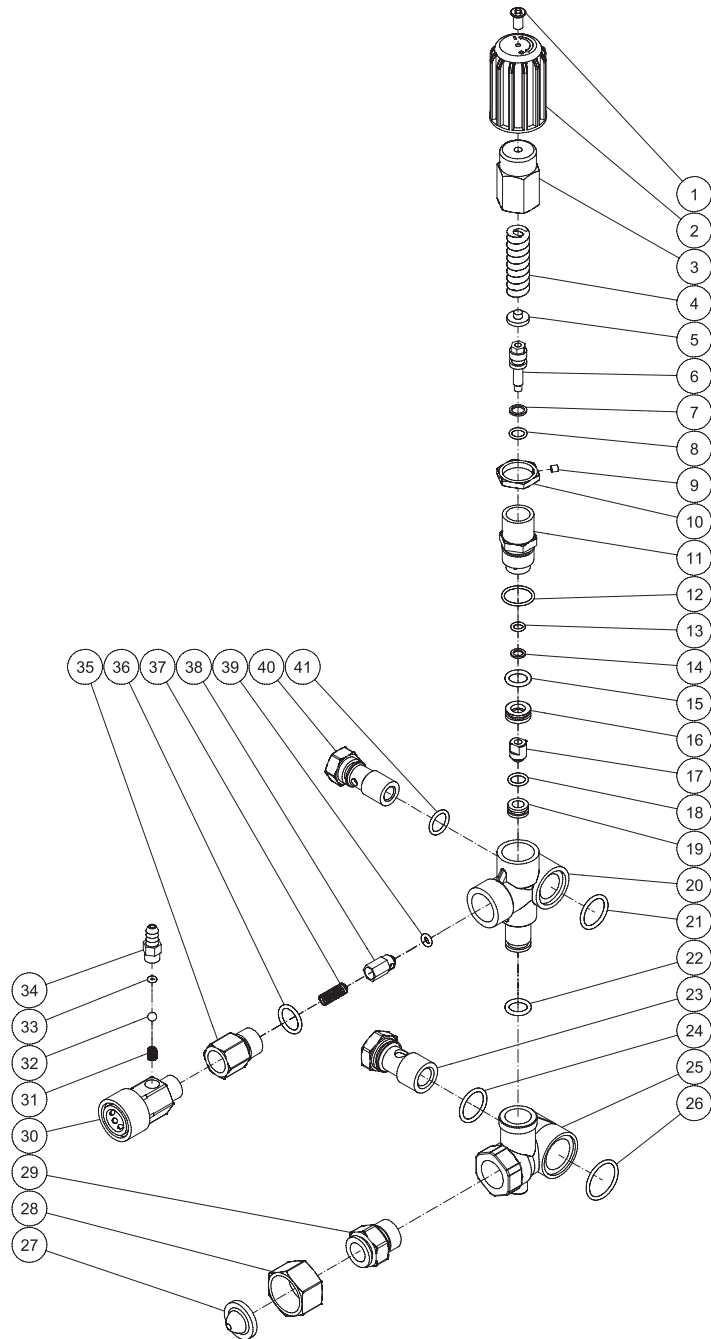

8-0632 102714 JDK

UNLOADER ASSEMBLY

ITEM	DESCRIPTION	PART #	QTY	ITEM	DESCRIPTION	PART #	QTY
1	SCREW (SEE KIT 70-0647)	27-2772	1	22	O-RING	25-0684	1
2	KNOB (SEE KIT 70-0647)	7-0250	1	23	INLET BANJO BOLT	8-0595	1
3	KNOB (SEE KIT 70-0647)	SEE KIT	1	24	O-RING	25-0602	1
4	SPRING (SEE KIT 70-0647)	SEE KIT	1	25	BY PASS HOUSING	N/A	1
5	SPRING SEAT (SEE KIT 70-0647)	SEE KIT	1	26	O-RING	25-0654	1
6	VALVE ROD (SEE KIT 70-0647)	SEE KIT	1	27	FILTER (SEE KIT 23-0095)	19-0001	1
7	SUPPORT RING (SEE KIT 70-0647)	SEE KIT	1	28	SWIVEL NUT (SEE KIT 23-0095)	SEE KIT	1
8	O-RING (SEE KIT 70-0647)	25-0651	1	29	INLET CONNECTOR (SEE KIT 23-0095)	SEE KIT	1
9	SET SCREW (SEE KIT 70-0647)	8-0479	1	30	QC ADAPTER (SEE KIT 70-0499)	SEE KIT	1
10	JAM NUT (SEE KIT 70-0647)	SEE KIT	1	31	SPRING (SEE KIT 70-0293 AND 70-0499)	SEE KIT	1
11	UNLOADER VALVE BODY (SEE KIT 70-0647)	SEE KIT	1	32	BALL (SEE KIT 70-0293 AND 70-0499)	SEE KIT	1
12	O-RING (SEE KIT 70-0647)	25-0652	1	33	O-RING (SEE KIT 70-0293 AND 70-0499)	SEE KIT	1
13	O-RING (SEE KIT 70-0647)	25-0163	1	34	HOSE BARB (SEE KIT 70-0499)	46-0869	1
14	SUPPORT RING (SEE KIT 70-0647)	SEE KIT	1	35	OUTLET CONNECTOR	46-1389	1
15	O-RING (SEE KIT 70-0647)	25-0655	1	36	O-RING	25-0386	1
16	BY PASS JET UNLOADER (SEE KIT 70-0647)	SEE KIT	1	37	SPRING (SEE KIT 70-0500)	SEE KIT	1
17	BULLET (SEE KIT 70-0647)	SEE KIT	1	38	CHECKING VALVE (SEE KIT 70-0500)	SEE KIT	1
18	O-RING (SEE KIT 70-0647)	25-0656	1	39	O-RING (SEE KIT 70-0500)	25-0653	1
19	VALVE SEAT (SEE KIT 70-0647)	SEE KIT	1	40	OUTLET BANJO BOLT	8-0594	1
20	VALVE HOUSING	N/A	1	41	O-RING	25-0169	1
21	O-RING	25-0664	1				

REPLACEMENT KITS

KIT #	DESCRIPTION	ITEMS	# OF ASSEMBLIES
23-0095	KIT - GARDEN HOSE INLET ASSY	27-29	1
70-0293	KIT - INJECTOR REPAIR	31-33	1
70-0499	KIT - OUTLET QC W/CHEM INJ	30-34	1
70-0500	KIT - NON-RETURN VALVE	37-39	1
70-0647	KIT - UNLOADER REBUILD	1-19	1

Manufactured by Mi-T-M
8650 Enterprise Drive, Peosta IA 52068
563-556-7484/ Fax 563-556-1235